

Thermal Imager Instruction Manual
Infrared Camera
Model: NF-521



Read the precautions carefully before operating the device

- The NF-521 system is powered by a lithium battery.
- Please do not place the device in dust, humidity, or heat (above 14°F to 113°F).
- Please use a battery that meets the specifications to avoid damaging the device.
- Please do not disassemble the device. A professional should do repair and maintenance.
- Please do not use this device to detect live power lines (such as 220V power supply lines), to avoid damaging it can cause safety concerns.

OVERVIEW

The NF-521 is a thermal imaging camera that combines surface temperature measurement and real-time thermal imaging. The thermal imager converts thermal radiation images into visible light images effectively. It is used for building diagnostics, industrial leak detection, electromechanical testing, etc.

It includes the following features:

1. SD Card Slot
2. USB interface
3. Power ON/OFF and Return Key
4. DOWN Key
5. UP Key
6. OK and MENU Key
7. Thermometer Lens
8. Infrared Camera
9. Trigger

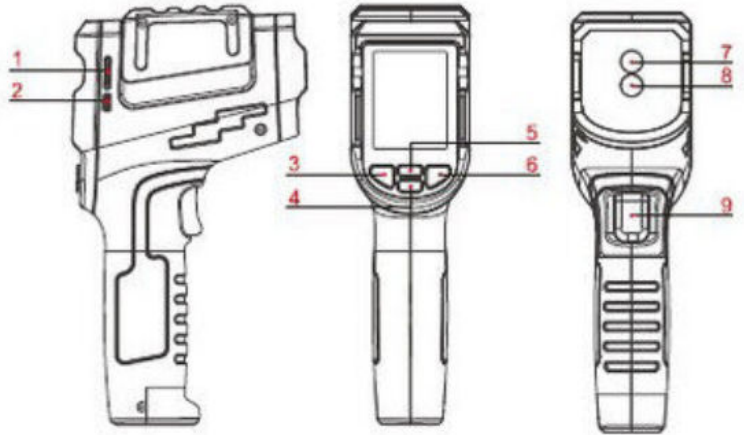

APPLICATION

- Installation and maintenance of floor heating, radiator, and water heater.
- Property maintenance such as air leaks.
- Electricity in buildings.
- Small animal search and investigation in buildings (including termite control).
- Car repair and maintenance inspection.
- Fire and rescue situation investigation.
- Hot water leaks under concrete slabs

CHARGING

When power is on, the battery symbol in the upper right corner of the screen represents the current power. When the battery symbol turns red, it means that it needs to be charged right now, otherwise it will be automatically shut down due to low battery. When charging, use the Micro USB data cable and plug it into the 5V charger for charging.

When the charger powers on, the charging symbol in the upper right corner of the screen turns green and the charging status is dynamically displayed. When power is off, the battery symbol in the center of the screen dynamically displays the charging state.